

4

3

2

1

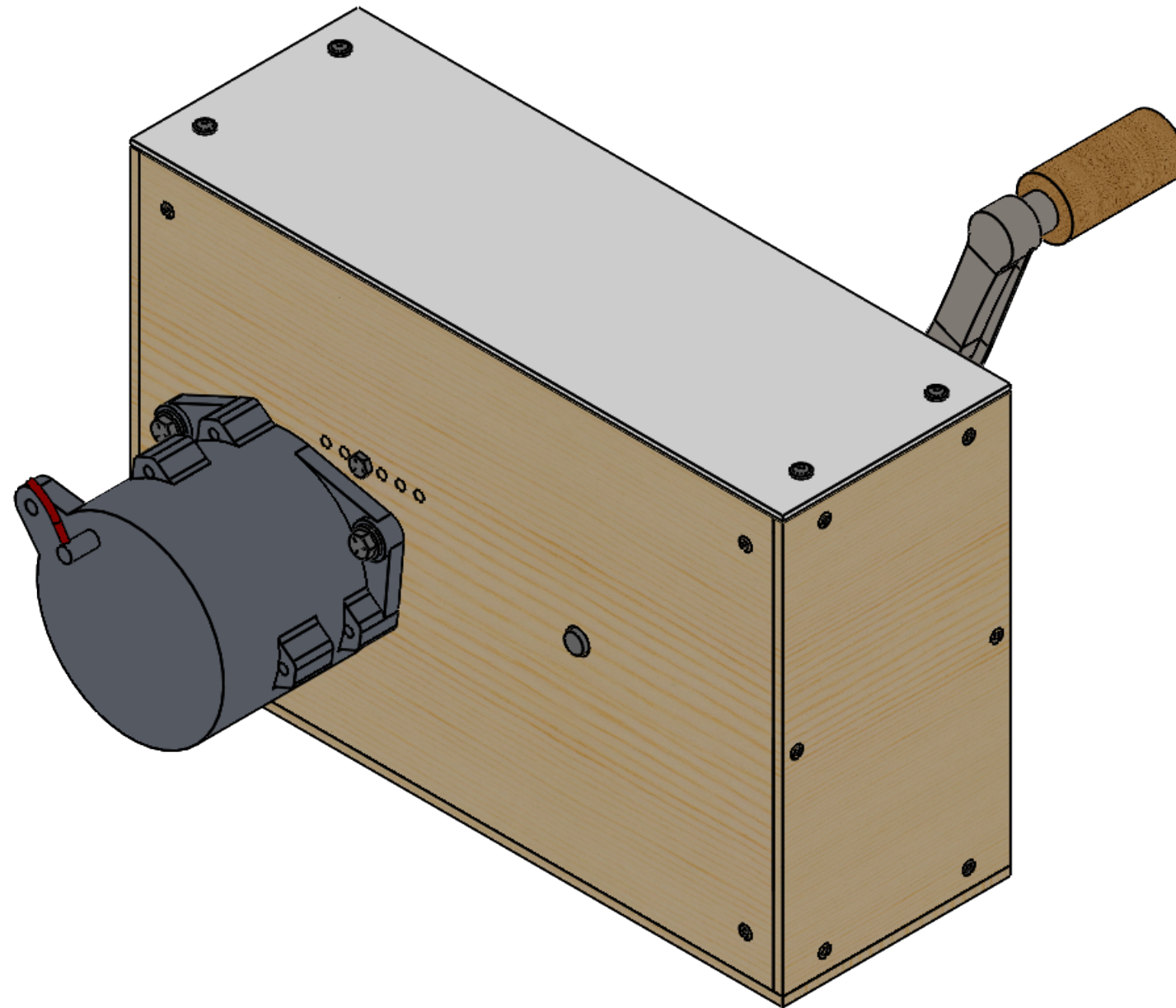

ITEM NO.	PART NUMBER	DESCRIPTION	Default/ QTY.
1	N00046	GEARBOX SIDE X	2
2	N00047	GEARBOX SIDE Y	1
3	N00048	GEARBOX SIDE Y CLEAR	1
4	N00020	TENSIONER SPACER	2
5	AN00007	ALTERNATOR SUBASSEMBLY	1
6	AN00015	GEARBOX SIDE#S SUBASSEMBLY	1
7	N00026	1_4-20 2INL HEX HEAD BOLT	2
8	N00027	1_4-20 HEX NUT	2
9	N00035	1_4-20 NYLOCK NUT	2
10	N00041	5_16-18 1_25INL HEX HEAD BOLT	2
11	N00040	5_16 WASHER	2
12	N00031	#8-32 TEE NUT INSERT	4
13	N00029	#8 WASHER	4
14	N00030	#8-32 1_2 INL BUTTON HEAD SCREW	4
15	N00064	DRYWALL SCREWS 1INL	18

IOWA STATE UNIVERSITY MECHANICAL ENGINEERING DEPARTMENT

UNLESS OTHERWISE SPECIFIED:

DIMENSIONS ARE IN INCHES
 TOLERANCES:
 ANGULAR: ± 3 DEGREE
 TWO PLACE DECIMAL $\pm .05$
 THREE PLACE DECIMAL $\pm .005$

MATERIAL

SEE DRAWINGS

DO NOT SCALE DRAWING

SCALE 1:3

NAME	DATE
DRAWN JR	2-4-18
CHECKED JD	2-5-18

NOTES/COMMENTS:

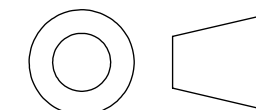

INTERPRET GEOMETRIC TOLERANCING PER: ASME Y14.5

TEAM: ME 270 EXAMPLE

TITLE:

GEARBOX SUBASSEMBLY

SIZE

B

PART NO.

AN00009

REV

2

VOLUME:

SHEET 1 OF 2

4

3

2

1

A

B

A

4

3

2

1

B

B

A

A

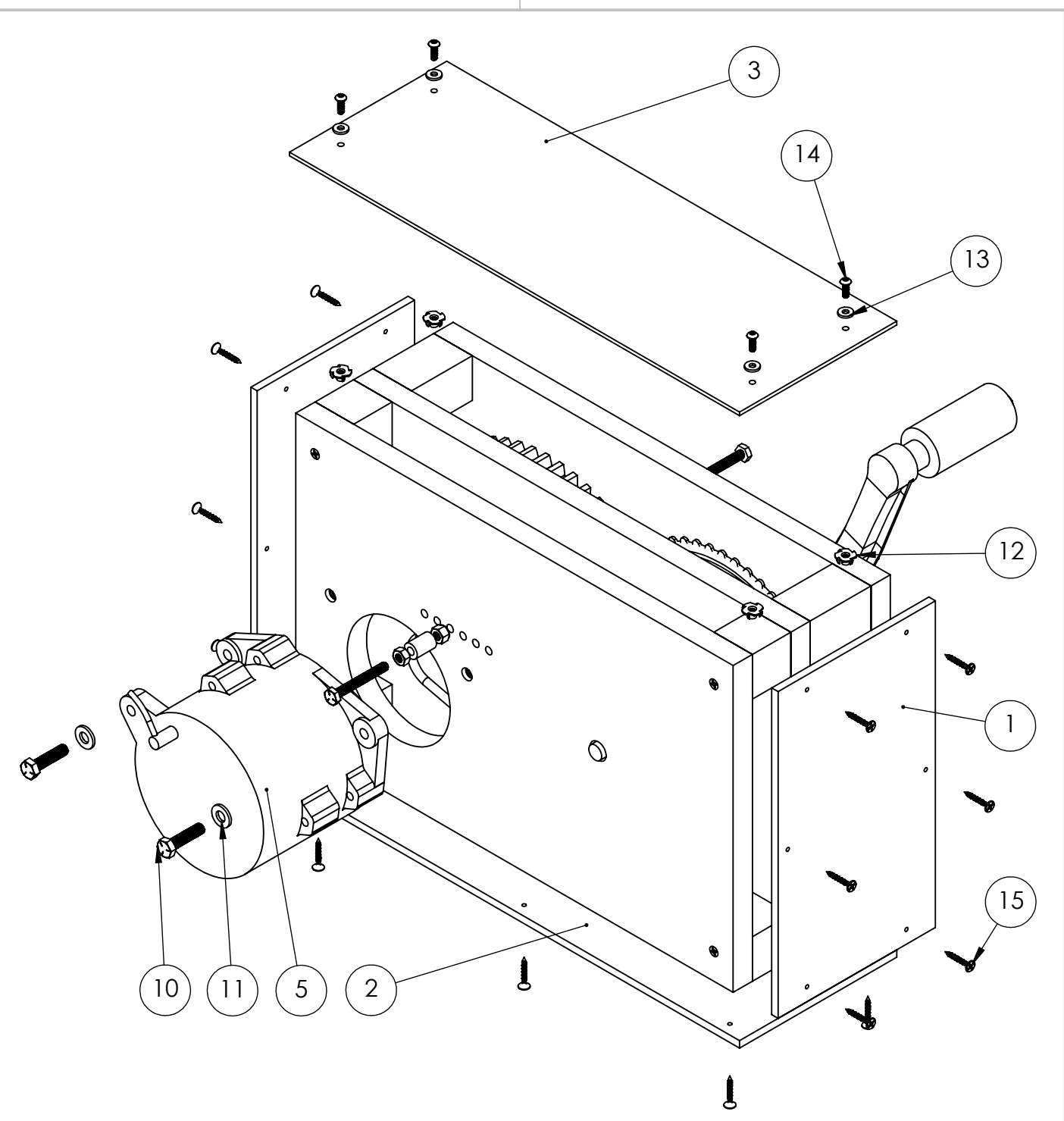
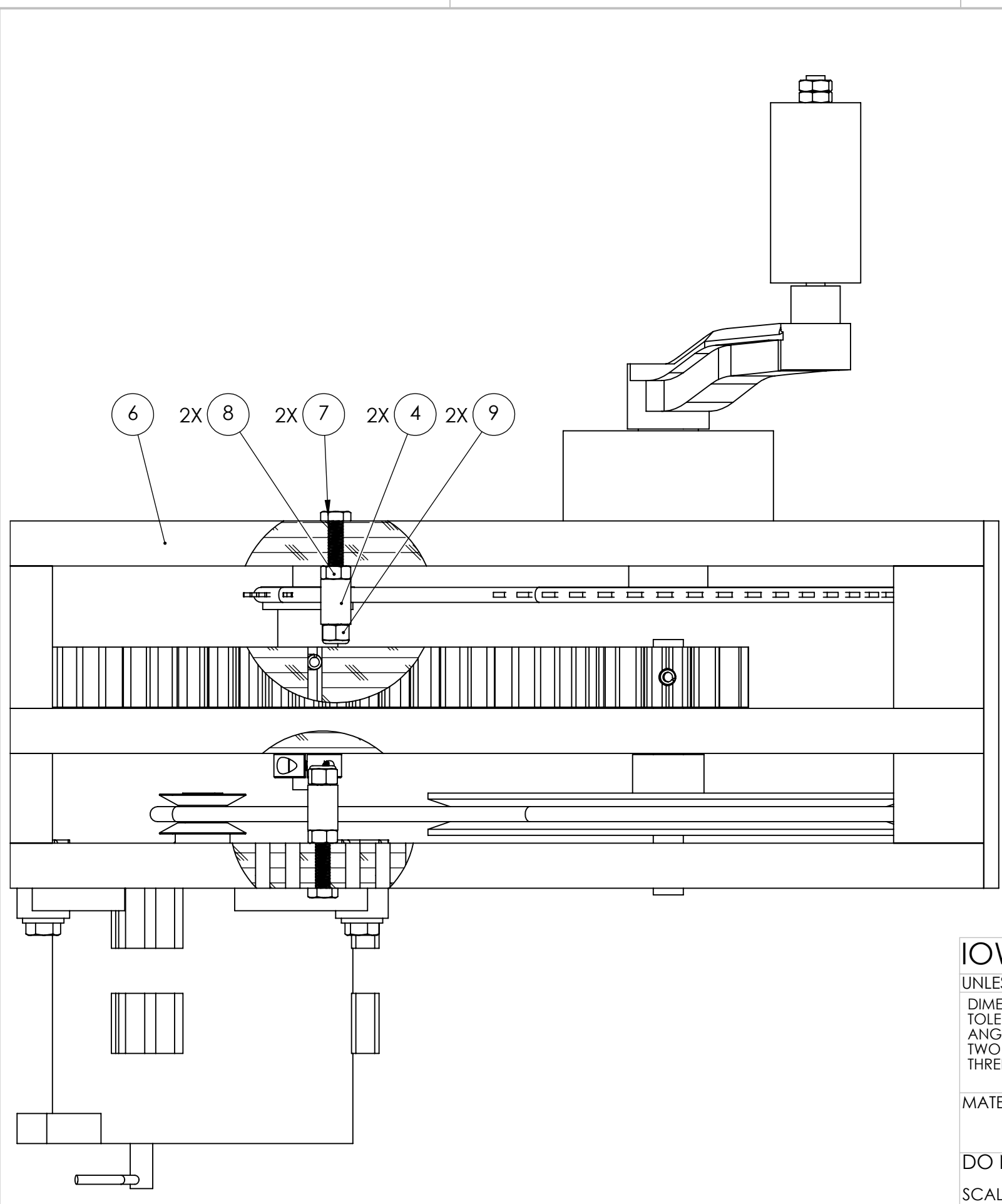

IOWA STATE UNIVERSITY MECHANICAL ENGINEERING DEPARTMENT

UNLESS OTHERWISE SPECIFIED:
 DIMENSIONS ARE IN INCHES
 TOLERANCES:
 ANGULAR: ± 3 DEGREE
 TWO PLACE DECIMAL ± .05
 THREE PLACE DECIMAL ± .005

DRAWN	NAME	DATE
CHECKED	JR	2-4-18
	JD	2-5-18

TEAM: ME 270 EXAMPLE

MATERIAL SEE DRAWINGS

NOTES/COMMENTS:

TITLE: GEARBOX SUBASSEMBLY

DO NOT SCALE DRAWING

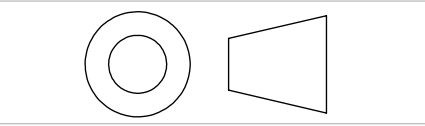

SIZE	PART NO.	REV
B	AN00009	2

SCALE 1:2

INTERPRET GEOMETRIC TOLERANCING PER: ASME Y14.5

VOLUME: SHEET 2 OF 2

4

3

2

1